



Pedal to the Metal:

***How Green Financing Can
Accelerate Sustainable
Construction and Retrofits***

***Dakota Gale
Sustainable Finance Director
Earth Advantage Institute***



Primary Initiatives



Mortgage

Insurance

Appraisal

MLS

And More!

Mortgages



Mortgage Barriers



Compliance

Banks like \$\$\$

Mortgage Products



Umpqua Bank: \$1,564 credit

Premier Mortgage: \$2,500



Insurance



Insurance Barriers

A close-up photograph of a brick wall with reddish-brown bricks and grey mortar, serving as the background for the central text.

Defensibility

Substantial

Insurance Products



Fireman's Fund: 5% discount

Liberty Mutual: 10% discount



Appraisals





Addendum

Green Premium

MLS



Multiple

Listing

Service

MLS: Disclosure

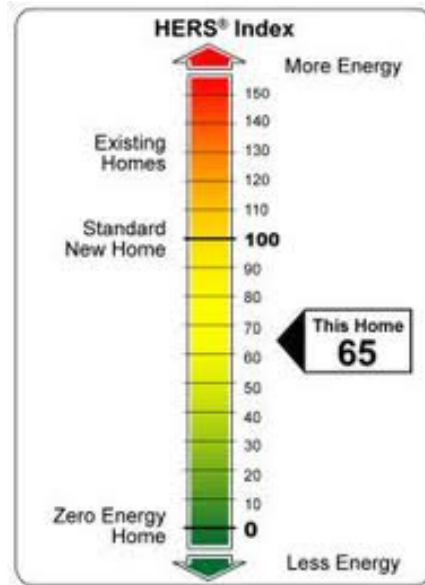

ENERGY PERFORMANCE SCORE

Address: 6876 Elm St, Portland, OR 97212 Reference Number: 410000000

Energy Use: 21,100 kWh/yr **51.157** Carbon Emissions: 15,700 lbs/yr

Electric: 7,300 kWh/yr 8588 Electric: 10,200 lbs/yr

Natural Gas: 470 therms/yr 6559 Natural Gas: 5,500 lbs/yr

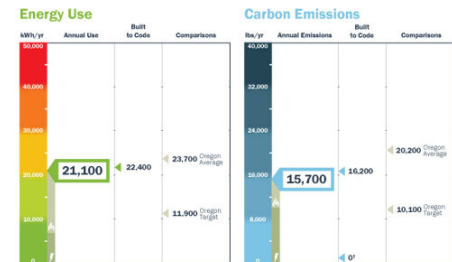

This score measures the total energy use (electricity, natural gas, propane, heating oil) of this home for one year. The lower the score, the less energy required for normal use. Actual consumption and costs may vary. Measured in kilowatt hours per year (kWh/yr).

This score measures the total carbon emissions based on the annual amounts, types, and sources of fuels used in this home. The lower the score, the less carbon is released into the atmosphere to power this home. Measured in pounds of carbon per year (lbs/yr).

Size: 1,911 sq ft Audit Date: 9/17/2008
 Type: Single Family Auditor: Earth Advantage Institute
 Bedrooms: 4 Portland, OR
 Year Built: 2008 E. Storm

Visit www.energystar.gov/eps for tips to maximize energy savings.



MLS: Quality Assurance





Competition

Database

Legislation



HB3535



EPS Auditor



For Homeowners

For Professionals

About

FAQ

Contact

What is EPS?

We want you to have a more comfortable, safe, and energy efficient home. Energy professionals can help you make that happen.

The Energy Performance Score ("EPS" for short) is an exciting new tool that provides a standardized estimate of a home's energy use and associated carbon emissions. The EPS allows for comparisons of one home's energy use to another, without the influence of varying occupant behavior. Homeowners can also use the tool to compare the typical energy use of the house in its current state versus what it could be like after energy upgrades.

Bellingham, WA

Community Energy Challenge: A Whatcom County Green Jobs and Energy Efficiency Program

The Community Energy Challenge makes achieving energy efficiency as easy as possible from start to finish. We provide each participating household and business with quality information, a full energy assessment...

[Find out more...](#)

The Seattle Energy Performance Score Program

How it Works



Audit Your Home

The first step is to analyze your home's energy efficiency and identify opportunities for improvement. An Energy Performance Score (EPS) audit can do just that! A certified EPS auditor can inspect your home and provide a Scorecard that assesses current energy consumption and predicts what the savings would be after making improvements. Along with the Scorecard, a detailed Energy Analysis and Upgrades report explains the auditor's recommended upgrades and analyzes their impact on energy and cost reduction.

[More >>](#)



Upgrade Your Home

After reviewing the results of your EPS audit, your next step is to implement the recommendations. While you can make some minor fixes yourself, we recommend that you contact a professional contractor that specializes in energy retrofit projects. Through our participating programs, we can help you find qualified contractors in your area.

[More >>](#)



Financing Options

Home improvement can be expensive, but luckily there are many tax rebates and financing programs available to help with these costs. We can help you learn about all the different options.

Log in to My Account

Username

demo_home

Password

[Forgot Password?](#)

Remember me

[Log In](#)

Don't Have an Account?

[Contact Us](#) for more information about how you can access the EPS Web Interface Portal



203(k) & EEMs

Market Uptake

Financing Mechanisms



Clean Energy Works

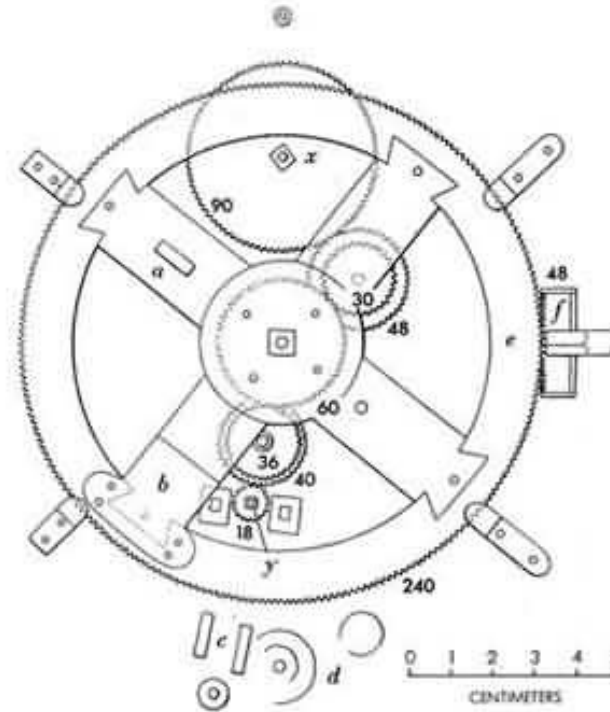

Financing Mechanisms



AFC First

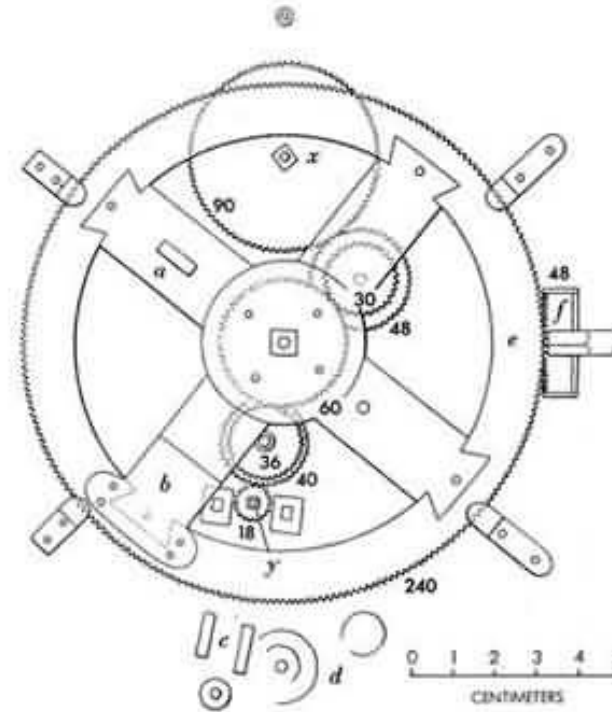

Questions?



Contact Information



Dakota Gale

Sustainable Finance Director

Earth Advantage Institute

503-968-7160

dgale@earthadvantage.org